

Characteristics

- Wide input voltage range, non-isolated regulated single-channel output
- Efficiency: Up to 96%
- Operating temperature: $-40^{\circ}\text{C} \sim +85^{\circ}\text{C}$
- No-load input current as low as 0.1mA
- Output short-circuit protection
- Pin-compatible with the LM78xx series
- Small SIP package, plastic housing

Wide-input-voltage, non-isolated, single-output DC-DC power supply module

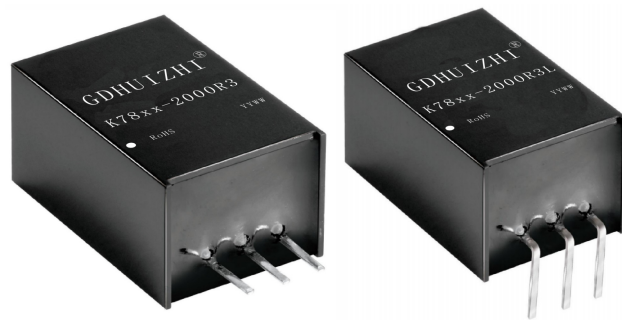

The K78xx-2000R3 series consists of highly efficient switching regulators that serve as ideal replacements for the LM78xx series of three-terminal linear regulators. These regulators feature high efficiency, low no-load power consumption, and short-circuit protection, while requiring no external heat sink and supporting negative output. The products are widely applicable in various industries, including industrial control, power, and instrumentation.

Model Number Description

K78 xx -2000 R3

Suffix (3rd-generation product)
 Output rated current (2000mA)
 Output voltage (rated)
 Product series

K78 xx -2000 R3 L

Pin 90° bended
 Suffix (3rd-generation product)
 Output rated current (2000mA)
 Output voltage (rated)
 Product series

Product selection table

Certification	Model number	Input voltage range (Vdc)	Output voltage/current		Ripple and Noise	Efficiency @ Full Load
		Rated value [®] (Range)	Output V. (Vdc)	Output C. (mA) (Max. Min.)	Full load (mVp-p) TypMax.	% Min. / Max.
	K78X2-2000R3	24 (4.5-28)	1.8	2000	30/75	83/79
	K7802-2000R3	24 (4.5-36)	2.5	2000	30/75	89/83
		12 (8-32)	-2.5	1000	30/100	86/80
	K7803-2000R3 (L)	24 (6-36)	3.3	2000	30/75	89/85
		12 (8-31)	-3.3	1000	30/100	85/83
	K7805-2000R3 (L)	24 (8-36)	5	2000	30/75	89/87
		12 (8-30)	-5	1000	30/100	86/84
	K78X6-2000R3 (L)	24 (10-36)	6.5	2000	30/75	92/89

		12 (8-29)	-6.5	1000	30/100	85/83
K7809-2000R3 (L)		24 (13-36)	9	2000	30/75	92/90
		12 (8-26)	-9	800	30/100	86/81
K7812-2000R3 (L)		24 (16-36)	12	2000	30/75	93/91
		12 (8-23)	-12	600	30/100	87/85
K7815-2000R3		24 (18-36)	15	2000	30/75	95/93
		12 (8-20)	-15	600	30/100	87/87

Note: 1. Due to space limitations, the above is only a list of typical products. For products not included in this list, please contact our Sales Department.

2. When the input voltage exceeds 30 VDC, a 22 μ F/50 V electrolytic capacitor must be connected to the input terminal to prevent damage to the module caused by voltage spikes.

3. K78xx-1000R3L denotes a pin 90° bended product.

Test Conditions: Unless otherwise specified, all parameter measurements were taken at the rated input voltage, with a purely resistive rated load, and at an ambient temperature of 25° C.

Input Characteristics

Items	Operating Conditions	Min.	Typ.	Max.	Unit
No-load input current (full load/no-load)	Positive output	--	0.1	1.0	mA
Reverse input		Prohibited			mA
Input filter type (Isec.max)		Capacitive filtering			VDC
Hot swap		Not supported			

Output Characteristics

Items	Operating and Test Conditions		Items	Typ.	Max.	Unit
Output voltage accuracy	Full load, input voltage range	Output voltage	--	± 2	± 4	%
		other models	--	± 2	± 3	%
Linear adjustment	Full load, input voltage range		--	± 0.4	± 0.8	%
Load adjustment	10%~100% load		--	± 0.5	± 2	%
Ripple & Noise	Positive output, 20 MHz bandwidth, peak-to-peak, 100% load.		--	30	75	mVp-p
	Negative output, 20 MHz bandwidth, peak-to-peak, 100% load		--	30	100	
Temperature drift coefficient	Operating temperature -40° C to +85° C		--	--	± 0.03	%/° C
Transient response deviation	Rated input voltage, 25% load step change		--	± 50	± 150	mVp-p
During transient recovery			--	0.2	1	ms

Output short-circuit protection		Long-term short circuit, automatic recovery	-
---------------------------------	--	---	---

Note: ① The test method for ripple and noise is the twisted-pair test method.
② At loads below 10%, the maximum ripple and noise for the 3.3V/5V outputs is 150 mVp-p, and the maximum ripple and noise for the 9V/12V/15V outputs is 2% of the output voltage (Vo).

General Characteristics

Items	Operating Conditions	Min.	Typ.	Max.	Unit
Operating temperature	Use the reference temperature derating curve	-40	--	+85	°C
Storage temperature		-55	--	+125	
Temperature rise of the housing during operation		--	25	--	
Storage humidity	No condensation	5	--	95	%RH
Pin soldering temperature	The solder joint is 1.5 mm from the housing, 10 seconds (max.)	--	--	+260	°C
Switching frequency	Full load, rated voltage input	--	400	--	KHz
Vibration		10-55Hz, 10G, 30 Min. along X, Y and Z			
Housing material		Black flame-retardant heat-resistant plastic (UL94 V-0)			
Package size	K78xx-2000R3	11.60x9.0x17.50mm			
	K78xx-2000R3L	19.0x11.6x9.0mm			
Weight	3.8g (Typ.)				
Cooling method	Natural cooling				
Minimum mean time between failures	MIL-HDBK-217F@25°C	2000	--	--	KHrs

Product Characteristics Curve

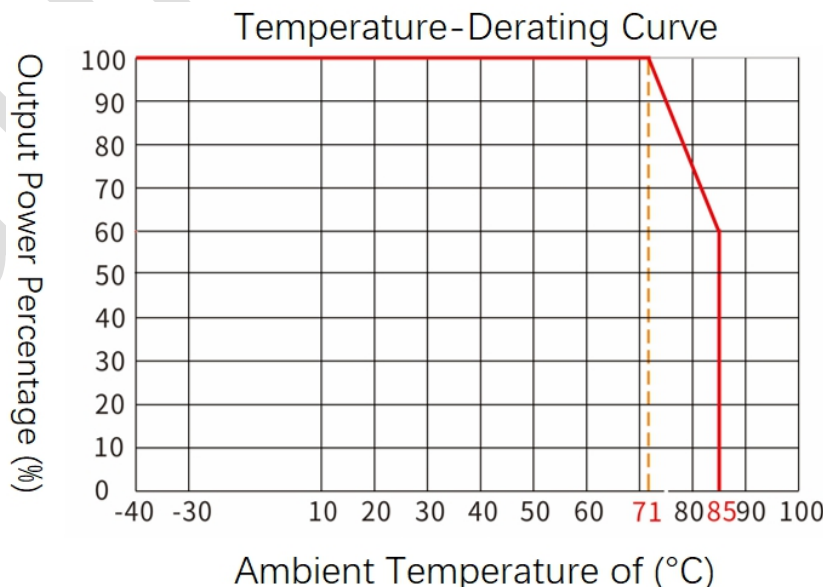

Typical Application Reference Circuit (Recommended Parameters)

1. Common Applications:

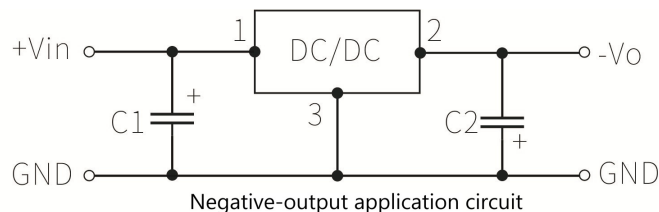
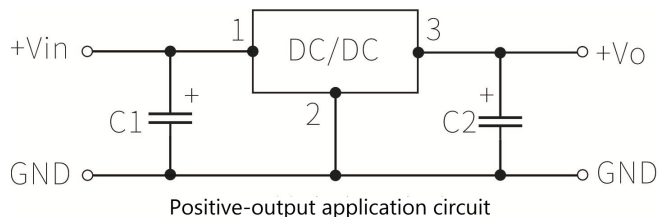

Figure 1: Typical Application Circuit

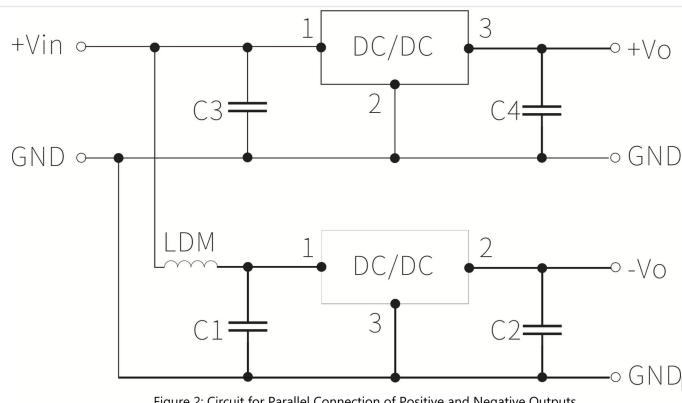

Table 1

Model No.	C1/C3 (Ceramic capacitor)	C2/C4 (Ceramic capacitor)
K78X3-2000R3	22 μ F/50V	22 μ F/10V
K7802-2000R3		22 μ F/10V
K7803-2000R3 (L)		22 μ F/10V
K7805-2000R3 (L)		22 μ F/10V
K78X6-2000R3 (L)		22 μ F/10V
K7809-2000R3 (L)		22 μ F/16V
K7812-2000R3 (L)		22 μ F/25V
K7815-2000R3		22 μ F/25V

Note:

- Under normal circumstances, external capacitors C1 and C2 (C3 and C4) should be connected based on the product's operating environment, and these capacitors should be placed close to the product's pins;
- Refer to Table 1 for the capacitance values of C1 and C2 (C3 and C4); these values may be increased as needed, and low-ESR tantalum or electrolytic capacitors may be used;
- When the product is used in the application circuit shown in Figure 2, it is recommended to add an inductor LDM to reduce mutual interference between products; the recommended value for LDM is 10 μ H;
- This product does not support hot-swapping, and the output terminals must not be used in parallel;
- If further reduction of output ripple is required, an external "LC" filter network can be added to the output terminals. The recommended value for L is 10 μ H - 47 μ H, and the recommended value for C5 is 22 μ F, as shown in Figure 3.

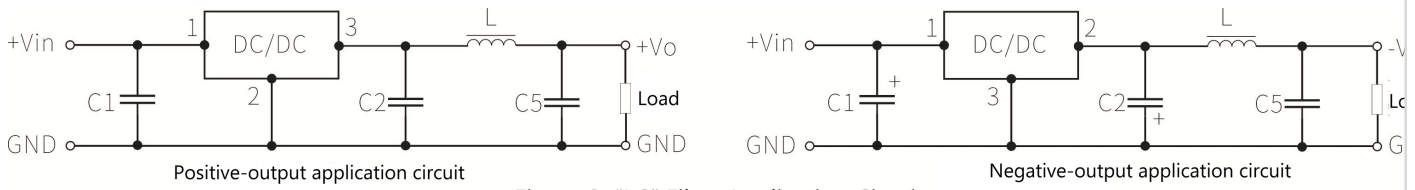

Figure 3: "LC" Filter Application Circuit

2. Recommended EMC Circuits

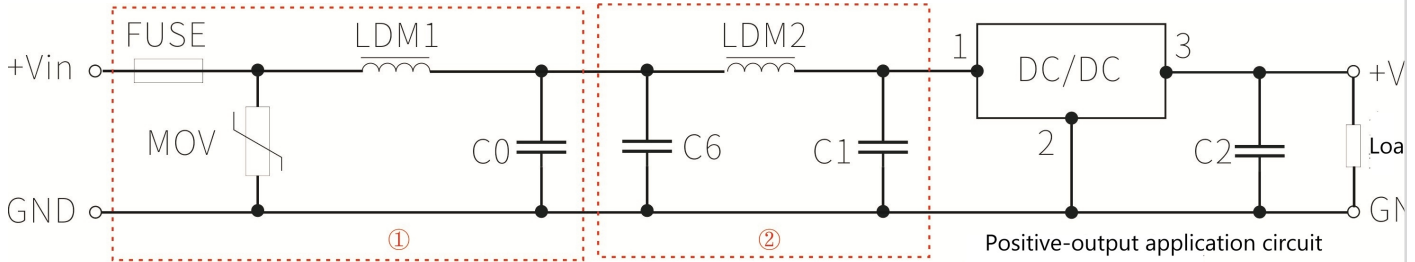

Figure 4: EMC Recommended Application Circuit

FUSE	MOV	LDM1	C ₀	C1/C2	C ₆	LDM2
Select based on the customer's actual input current	20D470K	82uH	680uF/50V	参照表 1	4.7uF/50V	12uH

Note: Part ① in Figure 4 is used for EMS testing; Part ② is used for EMI testing. You may select the appropriate recommended circuit based on your requirements.

Product Dimensions and Pin Assignment, Recommended PCB Layout

1) Dimensions

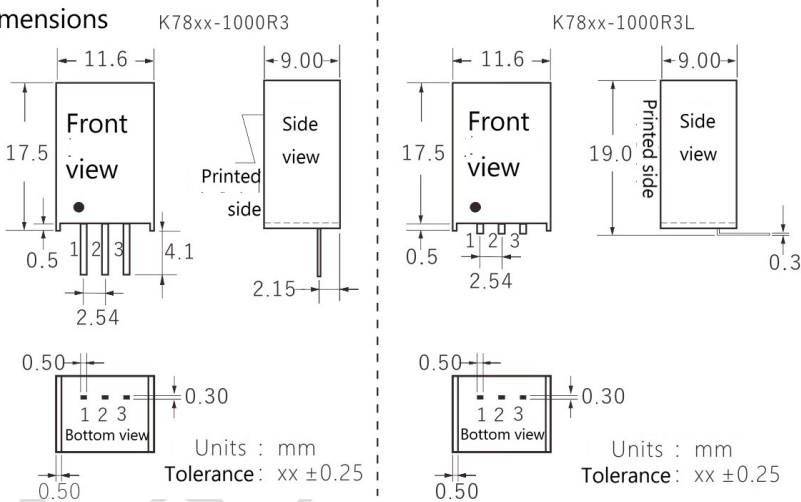

2) Pin Definitions

Pin	1	2	3
+ output	+Vin	GND	+Vo
- output	+Vin	-Vo	GND

3) Suggested PCB layout

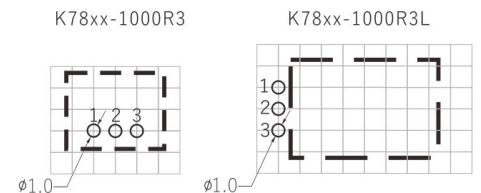

Note: Grid spacing: 2.54*2.54mm

*Note: If the pin assignments of the power module differ from those in the selection guide, refer to the labels on the actual unit.

Package Description

Package code		L x W x H
K78xx-2000R3	11.60x9.00x17.50mm	0.457 × 0.354 × 0.689inch
K78xx-2000R3L	19.00x11.60x9.00mm	0.748 × 0.457 × 0.354inch

Test Application Reference

Ripple & Noise Testing: (Twisted-pair method, 20 MHz bandwidth)

Test Method:

1、Ripple noise was measured using a Category 12 twisted-pair cable. The oscilloscope was set to a bandwidth of 20 MHz with a 100 MHz bandwidth probe, and a 0.1 μ F polypropylene capacitor and a 4.7 μ F high-frequency, low-impedance electrolytic capacitor were connected in parallel at the probe tip. The oscilloscope used the “Sample” mode for data acquisition.

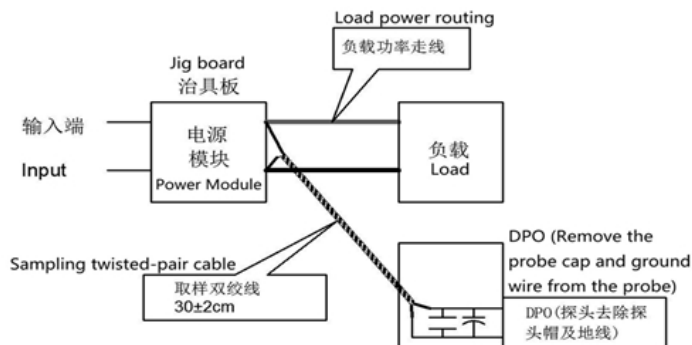

2. Schematic diagram for output ripple and noise testing:

Connect the power supply input to the input power source. Connect the power supply output to the electronic load via the fixture board. For testing, use a 30 cm \pm 2 cm test lead to take a direct sample from the power supply output port. Select insulated wires with an appropriate gauge based on the magnitude of the output current.

Precautions for Product Use

1. Input Requirements: Ensure that the output voltage fluctuation range of the power supply does not exceed the input requirements of the DC/DC module itself; the output power of the input power supply must be greater than the output power of the DC/DC module;
2. The capacitance of the external capacitor connected to the output should not be too large, otherwise it may cause overcurrent or poor startup of the module;
3. Maximum capacitive load values are tested within the input voltage range and under full-load conditions;
4. Unless otherwise specified, all specifications in this manual are measured at $T_a=25^\circ\text{C}$, humidity $<75\%$ RH, nominal input voltage, and rated output load;
5. All test methods for the specifications in this manual are based on our company's standards;
6. We offer product customization; please contact our technical staff directly for details;
7. Product specifications are subject to change without notice.

Contact

GDHUIZHI®

广东汇智电子技术有限公司

Guangdong Huizhi Electronic Technology Co., Ltd.

地址：广东省肇庆市端州区 11 区肇庆大道北侧厂房、办公楼(二期)3 楼

Add.: 3rd floor, factory and office building (phase II) on the north side of Zhaoqing Avenue,
District 11, Duanzhou District, Zhaoqing City, Guangdong Province, China

Homepage: www.huizhi-elec.com/www.chinaebizal.com

Tel: +86 - 758 - 2566 585

E-mail: sales@huizhi-elec.com

GDHUIZHI