

Features

- Wide input voltage non-isolated and regulated
- High efficiency up to 96%
- Operating ambient temperature: -40°C~+85°C
- Low no-load input current: as low as 0.2mA
- Output short-circuit protection
- Pin compatible with LM78xx series
- Small SIP package with plastic case

Wide Voltage Input, Non-Isolated Regulated
Single Output DC-DC Module Power Supply



RoHS

K78xxM-1000R3 series are high-efficiency switching regulator, serving as an ideal replacement for the LM78xx series of three-terminal linear regulators. It features high efficiency, low no-load power consumption, and short-circuit protection. No external heat sink is required during use, and it supports negative output. This product is widely applicable in industries such as industrial control, power systems, and instrumentation.

产品编码规则

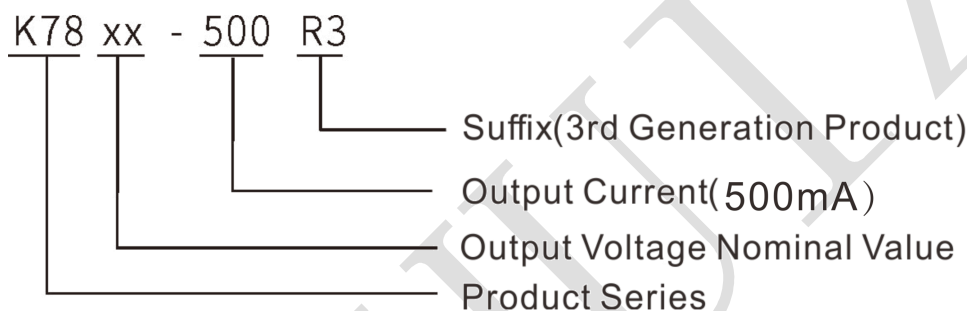

Selection Guide

Certification	Part No.®	Input Voltage (VDC)*	Output		Ripple and Noise	Efficiency @ Full Load
		Nominal (Range)	Voltage (VDC)	Voltage (VDC)	Full Load (mVp-p) Typ/Max.	% Min (Vin) / (typ.)
	K7803-500R3	24 (4.75-36)	3.3	500	20/75	80/86
	K7805-500R3	24 (6.5-36)	5	500	20/75	84/90
		24 (7-31)	-5	-300	20/75	80/81
	K7809-500R3	24 (12-36)	9	500	20/75	91/94
	K7812-500R3	24 (15-36)	12	500	20/75	91/94
		12 (8-24)	-12	-150	20/75	80/85

	K7815-500R3	24 (19-36)	15	500	20/75	93/95
		12 (8-21)	-15	-150	20/75	85/87

Notes:

- 1 · Due to space limitations, the above is only a list of typical products. For products not listed, please contact our sales department.
- 2 · When the input voltage exceeds 30VDC, an external 22uF/50V electrolytic capacitor is required at the input end to prevent module damage caused by voltage spikes.

Test Conditions:

Unless otherwise specified, all parameters are tested at nominal input voltage, pure resistive rated load, and 25°C room temperature.

Input Characteristics

Item	Operating Conditions	Min.	Typ.	Max.	Unit
No-load Input Current	Positive output	--	0.2	1.5	mA
Reverse Input		Prohibited			mA
Input Filter Type (Isec.max)		Capacitive filtering			VDC
Hot Swap		Not supported			

Output Characteristics

Item	Operating and Test Conditions	Min.	Typ.	Max.	Unit	
Output Voltage Accuracy	Full load, input voltage range	3.3V output	--	±2	±4	%
		Other models	--	±2	±3	%
Line Regulation	Full load, input	--	±0.2	±0.4	%	
Load Regulation	10%~100% load	3.3/5VDC output	--	±0.6	--	%
		Other models	--	±0.3	--	%
Ripple & Noise	Pure resistive load, 20MHz bandwidth, peak-to-peak, 10%-100% load	--	20	75	mVp-p	
Temperature	Operating temperature -40°C to +85°C	--	--	±0.03	%/°C	
Transient Response Deviation	Nominal input voltage, 25% load step change	--	50	250	mVp-	
Transient Recovery Time		--	0.2	1	ms	
Output Short-Circuit Protection		Long-term short circuit, auto-recovery			-	

Notes:

- ① The test method for ripple and noise is the twisted-pair test method.
- ② At loads below 10%, the maximum ripple & noise of 3.3V/5V output is 150mVp-p, and that of 9V/12V/15V output is 2%Vo.

General Specifications

Item	Operating Conditions	Min.	Typ.	Max.	Unit
Operating Temperature*	Refer to temperature derating curve	-40	--	+85	°C
Storage Temperature		-55	--	+125	
Case Temperature Rise During Operation		--	25	--	
Storage Humidity	No condensation	5	--	95	%RH
Pin Solder Resistance	1.5mm from case, max. 10s	--	--	+260	°C

Switching Frequency	Full load, nominal input voltage	--	650	--	KHz
Vibration		10-55Hz, 10G, 30 Min. along X, Y and Z			
Case Material		Black flame-retardant heat-resistant plastic (UL94 V-0)			
Package Dimension	11.60x7.55x10.16mm				
Weight	1.8g (Typ.)				
Cooling Method	Natural cooling				
MTBF	MIL-HDBK-217F@25°C	2000	--	--	KHrs

产品特性曲线图

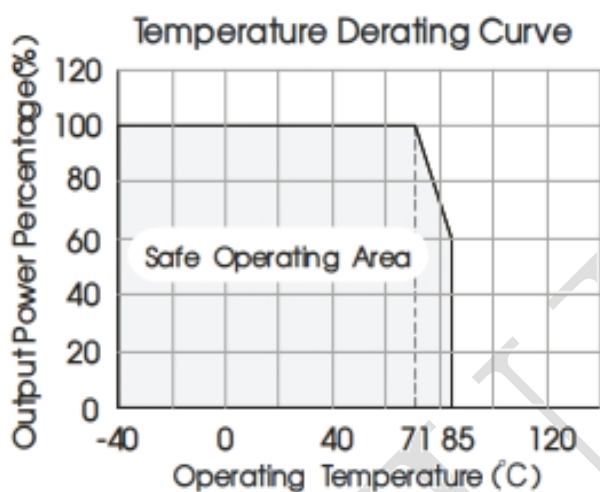

典型应用参考电路（推荐参数）

1. Typical Application:

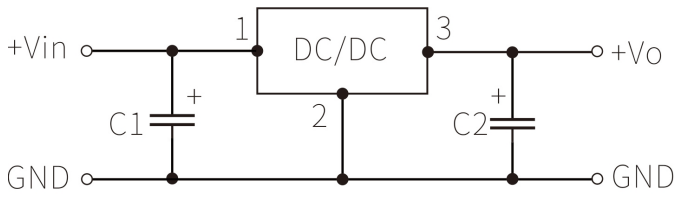

Positive Output Application Circuit

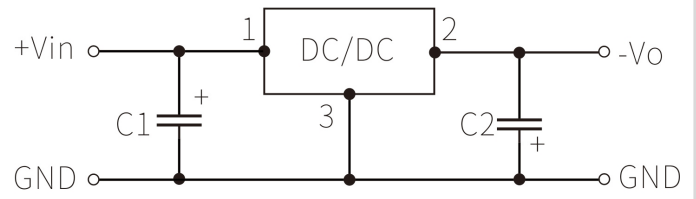

Negative Output Application Circuit

Figure 1: Typical Application Circuit

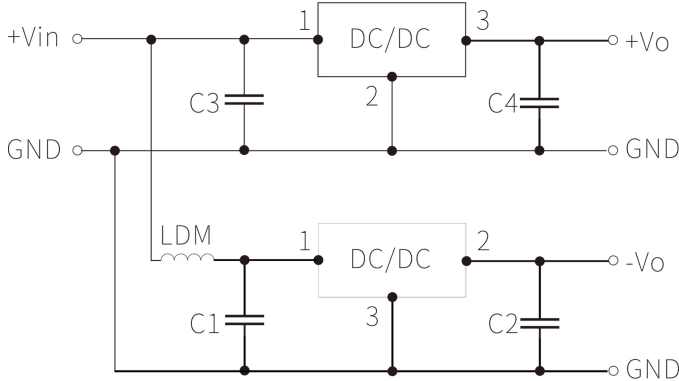

Fig 2: Parallel Application Circuit for Positive and Negative Outputs

Table 1

Product Model	C1/C3 (Ceramic Capacitor)	C2/C4 (Ceramic Capacitor)
K7803-500R3	10uF/50V	22uF/10V
K7805-500R3		22uF/10V
K7809-500R3		22uF/16V
K7812-500R3		22uF/25V
K7815-500R3		22uF/25V

Notes:

- Under normal circumstances, external capacitors C1 and C2 (C3 and C4) can be used according to the product's operating environment, and the capacitors should be placed close to the product's pins.
- The capacitance values of C1, C2 (C3, C4) refer to Table 1. They can be appropriately increased if needed, and low-ESR tantalum capacitors or electrolytic capacitors can also be used.
- When the product is used in the application circuit shown in Figure 2, it is recommended to add inductor LDM to reduce mutual interference. The recommended value of LDM is 10μH.
- This product does not support hot swapping, and the output ends cannot be used in parallel.
- To further reduce output ripple, an external "LC" filter network can be added at the output end. The recommended value of L is 10μH-47μH, and the recommended value of C5 is 22uF (as shown in Figure 3).

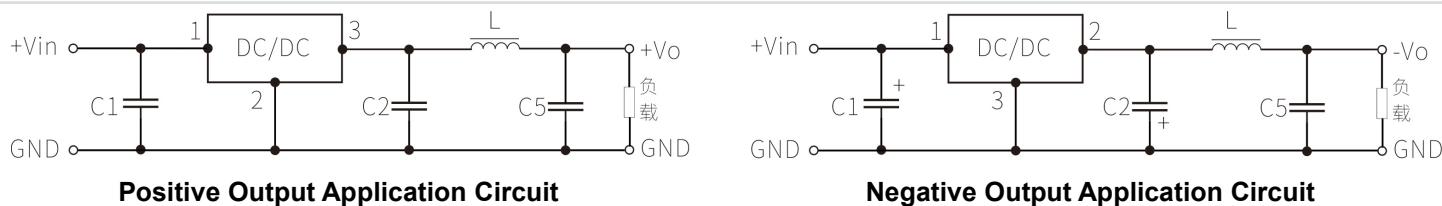

Fig3: 'LC' Filter Application Circuit

2. EMC Recommended Circuit

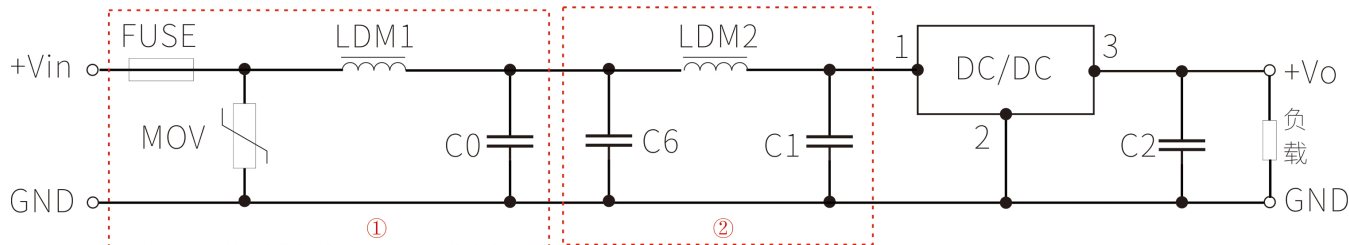

Fig 4: FMC Recommended Application Circuit

Positive Output Application Circuit

FUSE	MOV	LDM1	Co	C1/C2	C6	LDM2
Selected according to actual input current of the customer	20D470K	82uH	680uF/50V	Refer to Table 1	4.7Uf/50V	12uH

Note: Part ① in Figure 4 is used for EMS testing; Part ② is used for EMI testing. The appropriate recommended circuit can be selected according to requirements.

Product Appearance Dimension, Pin Definition, and Recommended PCB Layout

1. Dimensions (Unit: mm, Tolerance: ±0.25)

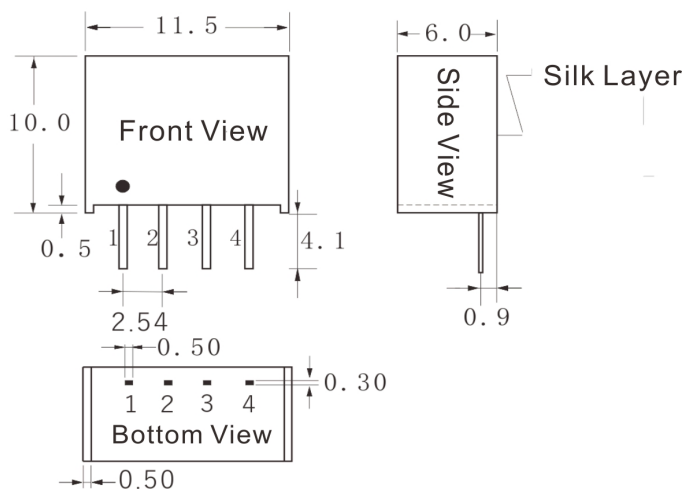

2. Pin Definitions

Pin-Out		
Pin	Positive Output	Negative Output
1	Vin	Vin
2	GND	-Vo
3	+Vo	GND

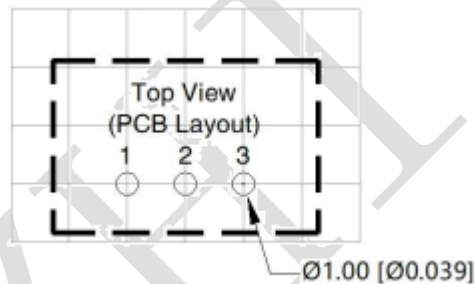

Note: Grid 2.54*2.54mm

3. Recommended PCB Layout Guidelines

**Note: If the pin definitions of the power module are inconsistent with the selection manual, the labels on the physical product shall prevail.*

Package Description

Package Code	L x W x H
-	11.60 x 7.55 x 10.16mm 0.457 × 0.297 × 0.400inch

Test Application Reference

Ripple & Noise Test: (Twisted-pair method, 20MHz bandwidth)

Test Method:

1. Ripple and noise are measured using 12# twisted-pair wires. The oscilloscope bandwidth is set to 20MHz, with a 100M bandwidth probe. A 0.1uF polypropylene capacitor and a 4.7uF high-frequency low-resistance electrolytic capacitor are connected in parallel at the probe end. The oscilloscope sampling uses the Sample mode.

2. Schematic diagram of output ripple and noise test:

Connect the input end of the power supply to the input power source, connect the power output to the electronic load through the fixture board, and use a separate 30cm±2cm sampling wire to sample directly from the power output port. The power line should be a insulated wire with appropriate diameter according to the output current.

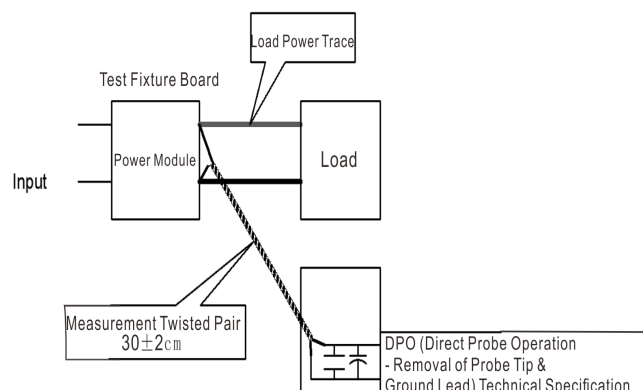

Product Application Notes

1. Input requirements: Ensure that the output voltage fluctuation range of the power supply does not exceed the input requirements of the DC/DC module itself, and the output power of the input power supply must be greater than that of the DC/DC module.
2. The capacitance of the external capacitor at the output end should not be too large, otherwise it may easily cause overcurrent or failure to start during module startup.
3. The maximum capacitive load is tested under the conditions of input voltage range and full load.
4. Unless otherwise specified, all indicators in this manual are measured at $T_a=25^{\circ}\text{C}$, humidity $<75\%RH$, nominal input voltage, and rated output load.
5. All test methods for indicators in this manual are based on the company's standards.
6. Our company can provide product customization. For details, please contact our technical personnel directly.
7. Product specifications are subject to change without prior notice.

Contact

GDHUIZHI®

广东汇智电子技术有限公司

[Guangdong Huizhi Electronic Technology Co., Ltd.](http://www.huizhi-elec.com)

地址：广东省肇庆市端州区 11 区肇庆大道北侧厂房、办公楼(二期)3 楼

Add.: 3rd floor, factory and office building (phase II) on the north side of Zhaoqing Avenue,
District 11, Duanzhou District, Zhaoqing City, Guangdong Province, China

Homepage: www.huizhi-elec.com/www.chinaebizal.com

Tel: +86 - 758 - 2566 585

E-mail: sales@huizhi-elec.com