

Typical characteristics

- Wide range input: 85-305VAC/80-432VDC
- No-load power consumption: 0.1W(Typ.)
- Conversion Efficiency: (Typ. 90%)
- Switching frequency: 65KHz
- Protection type: short circuit, overcurrent, overload
- Isolation voltage: 3750Vac
- Housing: plastic, UL94V-0 compliant
- Plug-in mounting on the PCB board
- CE and RoHS compliant

15W, wide-input-voltage, isolated regulated single-output (S)/dual-output with common ground (D)/dual-output isolated (E), AC-DC module power supply



RoHS

The HAW15\_S-F2, HAW15\_D-F2, and HAW15\_E-F2 series are compact, high-efficiency module power supplies offered by Huizhi Electronics.

This series of power supplies offers a wide range of input voltages, AC/DC compatibility, low ripple, low temperature rise, low power consumption, high efficiency, high reliability, high-level safety isolation, and excellent EMC performance. These products are widely used in various fields, including power, industrial, instrumentation, and smart home applications. When using these products in environments with poor electromagnetic compatibility, please refer to the EMC application circuits provided by our company.

Model Number Description



Product selection table

Certification	Model number	Output specifications				Maximum capacity sexual load	ripple and noise 20MHz (Max)	Efficiency @ full load, 220Vac (Typical)	
		Power	Voltage 1	Current 1	Voltage 2				Current 2
		W	Vo1 (V)	Io1 (mA)	Vo2 (V)				Io2 (mA)
	HAW15-220S05F2	15	5	3000	-	-	4000	80	83
	HAW15-220S09F2	15	9	1666	-	-	2200	80	86
	HAW15-220S12F2	15	12	1250	-	-	1000	80	88

HAW15-220S15F2	15	15	1000	-	-	1000	80	89
HAW15-220S24F2	15	24	625	-	-	470	80	90
HAW15-220D05F2	15	+5	1500	-5	1500	2200/2200	80	83
HAW15-220D09F2	15	+9	833	-9	833	1000/1000	80	86
HAW15-220D12F2	15	+12	625	-12	625	1000/1000	80	89
HAW15-220D15F2	15	+15	500	-15	500	470/470	80	89
HAW15-220D24F2	15	+24	313	-24	313	470/470	80	90
HAW15-220E05F2	15	+5	1500	+5	1500	2200/2200	80	83
HAW15-220E0512F2	15	+5	1500	+12	625	2200/1000	80	85
HAW15-220E0512F2A	15	+5	1000	+12	833	2200/1000	80	85
HAW15-220E0524F2	15	+5	1500	+24	313	2200/1000	80	85
HAW15-220E0524F2A	15	+5	1000	+24	400	2200/1000	80	85
HAW15-220E0524F2B	15	+5	2000	+24	200	2200/1000	80	85
HAW15-220E12F2	15	+12	625	+12	625	1000/1000	80	88
HAW15-220E12F2A	15	+12	900	+12	300	1000/1000	80	88
HAW15-220E24F2	15	+24	313	+24	313	470/470	80	89

Note 1: Due to space limitations, the above is only a partial product list. For products not listed, please contact our Sales Department.

Note 2: "\*" indicates models currently under development.

Note 3: Typical output efficiency values are based on measurements taken after the product has been aged under full load for 30 minutes.

Note 4: The full-load efficiency (% TYP) in the table has a tolerance of  $\pm 2\%$ . Full-load efficiency is calculated as the total output power divided by the module's input power.

Note 5: Adding a capacitive load to the output may cause output voltage instability under no-load or light-load conditions. We recommend using a load of at least 5% of the rated capacity.

## Input characteristics

Items	Working conditions	Minimum	Typical	Maximum	Unit
Input voltage range	AC input	85	220	305	VAC
	DC input	80	310	432	VDC
Input frequency range	-	47	50	63	Hz
Input current	115VAC	/	/	0.32	A
	220VAC	/	/	0.16	
Surge current	115VAC	/	/	10	
	220VAC	/	/	20	
Leakage current	-	0.5mA TYP/230VAC/50Hz			
External insurance management recommendation value	-	2A-4A/250VAC slow-break fuse			
Hot-swappable	-	Not supported			
Remote control	-	There is no remote control			

## Output characteristics

Items	Working conditions	Minimum		Typical	Maximum	Unit
Voltage accuracy	Input full voltage range	Vo1	-	$\pm 1.0$	$\pm 2.0$	%
		Vo2	-	$\pm 3.0$	$\pm 5.0$	%
Linear regulation rate	Rated load	Vo1	-	-	$\pm 0.5$	%
		Vo2	-	-	$\pm 1.5$	%
Load regulation rate	Input rated voltage 20%~100% load	Vo1	-	-	$\pm 1.0$	%
		Vo2	-	-	$\pm 3.0$	%
No-load power consumption	Input 115VAC	-		-	0.1	W
	Input 220VAC	-		-		
Minimum load	Single output	0		-	-	%
	Positive and negative dual co-ground output	10 (Load balancing)		-	-	%
	Positive and negative dual isolated outputs	10 (Load balancing)		-	-	
Startup delay time	Input rated Voltage (Full Load)	-		1000	-	mS
Power down hold time	Input 115VAC	-		10	-	mS
	Input 220VAC	--		60	-	
Dynamic response	25%~50%~25% 50%~75%~50%	Overshoot amplitude (%): $\leq \pm 5.0$				%
		Recovery time (mS): $\leq 5.0$				mS
Output overshoot	Input full voltage range	$\leq 10\%V_o$				%
Short-circuit protection		It can be short-circuited for a long time and self-recovering				Barrier type
Drift coefficient	-	-	$\pm 0.03\%$	-	-	%/°C
Overcurrent protection	Input full voltage range	$\geq 150\% I_O$ is self-recoverable				Barrier type
Ripple Noise	-	-	50	80	-	mV
	Note: The test method for ripple and noise uses the twisted-pair test method. For specific test procedures and equipment requirements, please refer to the section below (Ripple & Noise Test Instructions).					

## General characteristics

Items	Working conditions	Minimum	Typical	Maximum	Unit
Switching frequency	-	-	65	-	KHz
Operating temperature	-	-40	-	+75	°C
Storage temperature	-	-40	-	+85	

Soldering temperature	Wave soldering	260±4°C, time: 5-10S			
	Hand soldering	360±8°C, interval 4-7S			
Relative humidity	-	10	-	90	%RH
Isolation voltage	Input-output, test for 1 minute, leakage current ≤ 5mA	3750	-		VAC
Insulation resistance	Input-output @ apply DC500V	100	-		MΩ
Safety standards	-	EN60950、IEC60950			
Vibration	-	10-55Hz, 10G, 30Min, alongX, Y, Z			
Safety level	-	CLASS II			
Enclosure grade	-	UL94V-0 级			
Mean Time Between Failures (MTBF)	-	MIL-HDBK-217F@25°C >300,000H			

## EMC Electromagnetic Compatibility Characteristics

Total Project		Sub-projects	Testing standards	Judgment grade
EMC	EMI	Conducted Emission	CISPR22/EN55032	CLASS B
		Radiated Emission	CISPR22/EN55032	CLASS B
	EMS	Radiation Immunity	IEC/EN61000-4-3	10V/m Perf.Criteria B
		Conducted Susceptibility	IEC/EN61000-4-6	3Vr.m.s Perf.Criteria B
		Electrostatic Discharge	IEC/EN61000-4-2	Contact ±6KV / Air ±8KV Perf.Criteria B
		Surge Immunity	IEC/EN61000-4-5	±1KV Perf.Criteria B
		Electrical Fast Transient (EFT)	IEC/EN61000-4-4	±2KV Perf.Criteria B
		Immunity to Voltage Sag and Transient, Short Interruption	IEC/EN61000-4-11	0%~70% Perf.Criteria B

## Package Dimensions

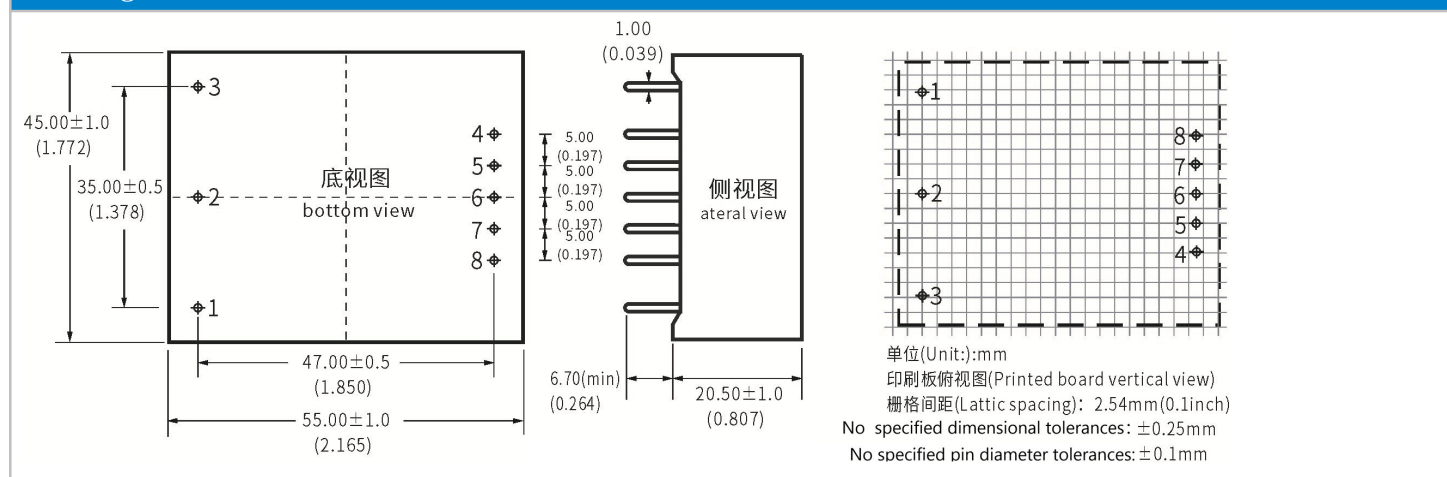

Package code	L x W x H	
F2	62.0 x 45.0 x 22.5 mm	2.441 × 1.772 × 0.885inch

**Pin Definitions**

Pin	1	2	3	4	5	6	7	8
Single (S)	FG	AC (N)	AC (L)	+Vo	NP	NP	NP	-Vo
	No function definition	Input neutral wire	Input line	Output positive terminal	Bare pin	Bare pin	Bare pin	Output negative terminal
Dual-channel common ground (D)	FG	AC (N)	AC (L)	+Vo1	NP	COM	NP	-Vo2
	No function definition	Input neutral wire	Input line	Output positive terminal 1	Bare pin	Common terminal	Bare pin	Output negative terminal 2
Dual-channel isolation (E)	FG	AC (N)	AC (L)	+Vo2	-Vo2	NP	+Vo1	-Vo1
	No function definition	Input neutral wire	Input line	Output positive terminal 2	Output negative terminal 2	Bare pin	Output positive terminal 1	Output negative terminal 2

Note: If the pin definitions of the power module differ from those in the selection guide, refer to the labels on the actual product.

**Ripple & Noise Test Instructions (Twisted Pair Method 20MHz Bandwidth)**

Test Method:

- Ripple noise is connected by 12# twisted pair wire, the oscilloscope bandwidth is set to 20MHz, the 100M bandwidth probe is set, and the 0.1uF polypropylene capacitor and 10uF high-frequency low-resistance electrolytic capacitor are connected in parallel on the probe end, & the oscilloscope sampling uses the Sample sampling mode.
- Schematic diagram for output ripple and noise testing:

Connect the power supply input to the input power source. Connect the power supply output to the electronic load via the fixture board. For testing, use a 30 cm ± 2 cm test lead to take a direct sample from the power supply output port. Select insulated wires with an appropriate gauge based on the magnitude of the output current.

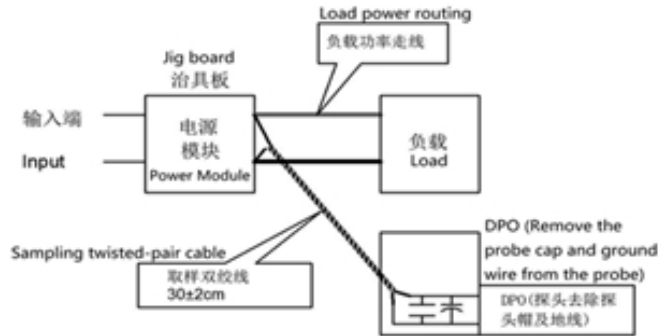

Product characteristic curve

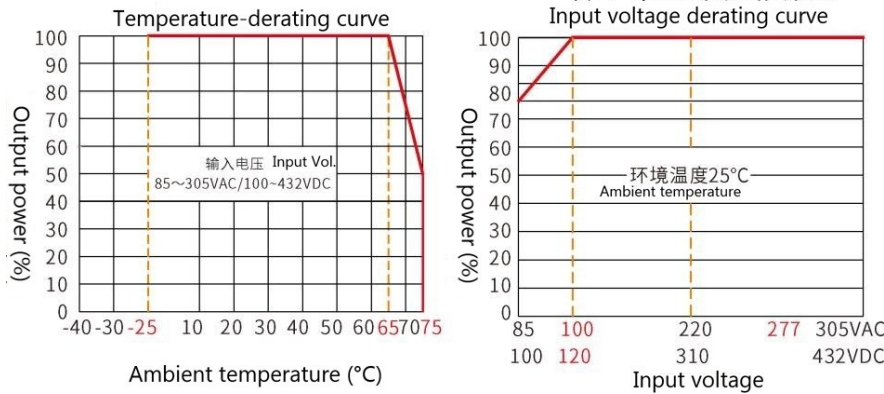

Note 1: When the input voltage is 85 - 100 VAC, derating must be performed based on the input voltage derating curve.

Note 2: This product is designed for use in naturally ventilated environments. Please contact us if you intend to use it in an enclosed environment.

Typical application circuit diagram and recommended parameters

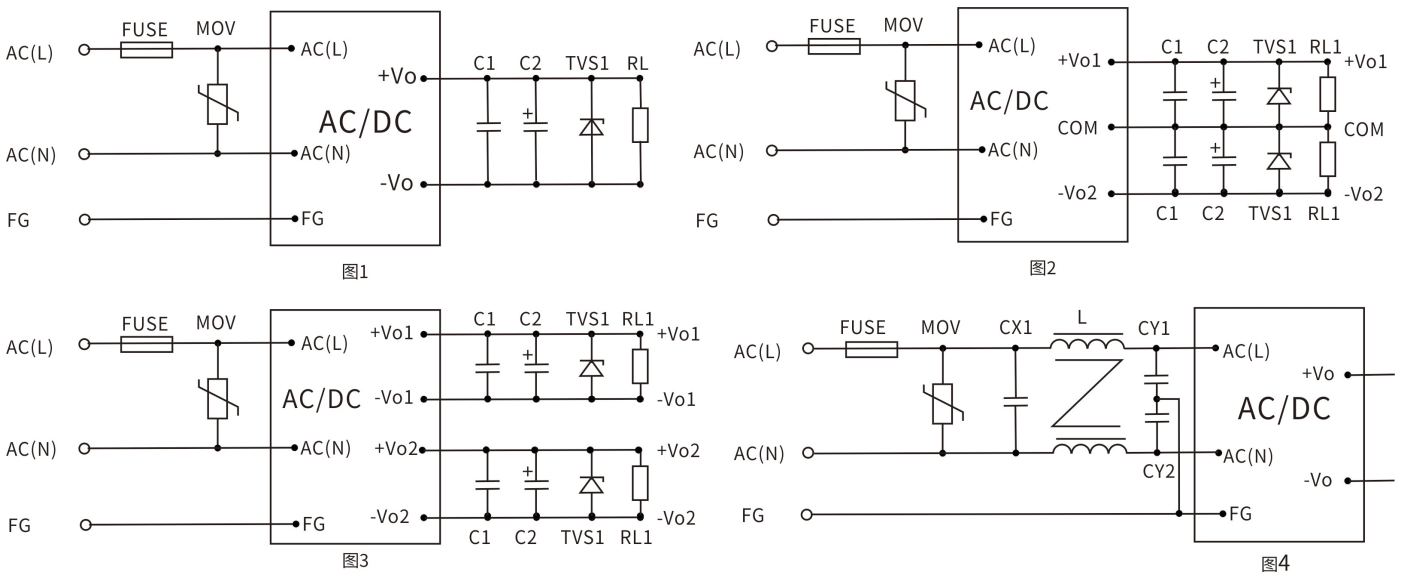

- Note:
- The output filter capacitors C1 and C3 are used to eliminate high-frequency noise. We recommend using 1  $\mu$ F ceramic capacitors with a voltage rating derated by more than 80%.
  - The output filter capacitors C2 and C4 are electrolytic capacitors. We recommend using high-frequency, low-impedance electrolytic capacitors with a rating of 100  $\mu$ F and 1A output current. The capacitors should have a voltage rating derated by more than 80%.
  - TVS diodes are recommended to protect the downstream circuitry (in case of module malfunction). Recommended 600W models: For 5V output, use SMBJ7.0A; for 9V output, use SMBJ12.0A; for 12V output, use SMBJ20A; for 15V output, use SMBJ20.0A; for 24V output, use SMBJ30.0A; for 48V output, use SMBJ64A.
  - MOV stands for Metal Oxide Varistor. Recommended models: 10D561K (1000V surge) or 14D561K (2000V surge). Its function is to protect the module from damage during lightning surges.
  - For general application requirements, customers should use the recommended circuits shown in Figures 1, 2, and 3. If higher EMC requirements are needed, please use the recommended circuit shown in Figure 4. The specific recommended values for Figure 4 are as follows:
    - Varistor (MOV): Recommended model: 14D-561K. Its function is to protect the module from damage during lightning surges.
    - Safety capacitors CY1 and CY2: 1000 pF/400 VAC;
    - Safety capacitors CY1 and CY2: 1000 pF/275 VAC;
    - Common-mode choke LCM: 20 mH - 30 mH;
    - FUSE (fuse): Mandatory; recommended rating: 3.15 A/250 V, slow-blow (if the fuse rating is too low, it may be damaged during a surge; if too high, it loses its protective function).

## Notes

1. The product must be used within the specified parameters; otherwise, it may be permanently damaged.
2. A fuse must be installed at the product's input terminal.
3. If the product operates below the minimum required load, we cannot guarantee that all performance specifications listed in this manual will be met;
4. If the product operates outside its rated load range, we cannot guarantee that all performance specifications listed in this manual will be met;
5. Unless otherwise specified, all data above was measured at  $T_a=25^{\circ}\text{C}$ , humidity  $<75\%$ , with nominal input voltage and rated output load (pure resistive load);
6. All test methods for the above specifications are based on our company's standards;
7. The specifications listed above apply to the product models specified in this manual. Certain specifications for non-standard models may exceed the requirements stated above; please contact our technical staff directly for details;
8. We offer product customization;
9. Product specifications are subject to change without notice; please refer to the latest version of the manual published on our official website.

## Contact

# GDHUIZHI®

## 广东汇智电子技术有限公司

[Guangdong Huizhi Electronic Technology Co., Ltd.](http://www.huizhi-elec.com)

地址：广东省肇庆市端州区 11 区肇庆大道北侧厂房、办公楼(二期)3 楼

Address: 3rd floor, factory and office building (phase II) on the north side of Zhaoqing Avenue,  
District 11, Duanzhou District, Zhaoqing City, Guangdong Province, China

Homepage: [www.huizhi-elec.com](http://www.huizhi-elec.com)/[www.chinaebizal.com](http://www.chinaebizal.com)

Tel: +86 - 758 - 2566 585

E-mail: [sales@huizhi-elec.com](mailto:sales@huizhi-elec.com)