

Typical characteristics

- Wide range input: 85-305VAC/100-432VDC
- No-load power: 0.1W(Typ.)
- Conversion efficiency: (Typ.90%)
- Switching frequency: 65KHz
- Protection: short circuit, overcurrent
- Isolation voltage: 4000Vac
- Housing: plastic, UL94V-0 compliant
- Through-hole mounting on a PCB
- CE and RoHS compliant

40W, wide-input-voltage, isolated regulated single-output (S)/dual-output with common ground (D)/dual-output isolated (E), AC-DC power module



RoHS

HAW40\_S-H2, HAW40\_D-H2, and HAW40\_E-H2 series are compact, high-efficiency module power supplies offered by Huizhi Electronics.

This series of power supplies offers a wide range of input voltages, AC/DC compatibility, low ripple, low temperature rise, low power consumption, high efficiency, high reliability, high-level safety isolation, and excellent EMC performance. These products are widely used in various fields, including power, industrial, instrumentation, and smart home applications. When using the products in environments with poor electromagnetic compatibility, please refer to the EMC application circuits provided by our company.

Model Number Description



Product selection table

Certification	Model number	Output specifications					Maximum capacity sexual load	ripple and noise 20MHz (Max)	Efficiency @ full load, 220Vac (Typical)
		Power	Vol. 1	Io 1	Vol. 2	Io 2			
		W	Vo1 (V)	Io1 (mA)	Vo2 (V)	Io2 (mA)			
	HAW40-220S05H2	40	5	8000	-	-	4000	80	83
	HAW40-220S09H2	40	9	4444	-	-	2200	80	86
	HAW40-220S12H2	40	12	3333	-	-	1000	80	88
	HAW40-220S15H2	40	15	2666	-	-	1000	80	89
	HAW40-220S24H2	40	24	1666	-	-	470	80	90

HAW40-220D05H2	40	+5	4000	-5	4000	2200/2200	80	83
HAW40-220D09H2	40	+9	2222	-9	2222	1000/1000	80	86
HAW40-220D12H2	40	+12	1666	-12	1666	1000/1000	80	89
HAW40-220D15H2	40	+15	1333	-15	1333	470/470	80	89
HAW40-220D24H2	40	+24	833	-24	833	220/220	80	90
HAW40-220E05H2	40	+5	4000	+5	4000	1000/1000	80	83
HAW40-220E0512H2	40	+5	4000	+12	1666	1000/1000	80	85
HAW40-220E0524H2	40	+5	4000	+24	833	1000/1000	80	85
HAW40-220E12H2	40	+12	1666	+12	1666	1000/1000	80	88
HAW40-220E24H2	40	+24	833	+24	833	470/470	80	89

Note 1: Due to space limitations, the above is only a partial list of products. For products not included in the list, please contact our Sales Department.

Note 2: "\*" indicates models currently under development.

Note 3: Typical output efficiency values are based on measurements taken after the product has been aged under full load for 30 minutes.

Note 4: The full-load efficiency (% TYP) in the table has a tolerance of  $\pm 2\%$ . Full-load efficiency is calculated as the total output power divided by the module's input power.

### Input characteristics

Items	Working conditions	Minimum	Typical	Maximum	Unit
Input voltage range	AC input	85	220	305	VAC
	DC input	80	310	432	VDC
Input frequency range	-	47	50	63	Hz
Input current	115VAC	/	/	1.00	A
	220VAC	/	/	0.50	
Surge current	115VAC	/	/	10	
	220VAC	/	/	20	
Leakage current	-	0.5mA TYP/230VAC/50Hz			
External insurance management recommendation value	-	2A-4A/250VAC slow-break fuse			
Hot-swappable	-	Not supported			
Remote control	-	There is no remote control			

### Output characteristics

Items	Working conditions	Minimum	Typical	Maximum	Unit	
Voltage accuracy	Input full voltage range Any load	Vo1	-	$\pm 1.0$	$\pm 2.0$	%
		Vo2	-	$\pm 3.0$	$\pm 5.0$	%
Linear regulation rate	Rated load	Vo1	-	-	$\pm 0.5$	%
		Vo2	-	-	$\pm 1.5$	%

Load regulation rate	Input rated voltage 20%~100% load	Vo1	-	-	±1.0	%
		Vo2	-	-	±3.0	%
No-load power consumption	Input 115VAC	-	-	0.1	W	
	Input 220VAC	-	-			
Minimum load	Single output	0	-	-	%	
	Positive and negative dual co-ground output	10(balance load)	-	-	%	
	Positive and negative dual isolated outputs	10(balance load)	-	-		
Startup delay time	Input rated Voltage (Full Load)	-	1000	-	mS	
Power down hold time	Input 115VAC (full load)	-	10	-	mS	
	Input 220VAC (full load)	--	60	-		
Dynamic response	25%~50%~25% 50%~75%~50%	Overshoot amplitude (%): $\leq \pm 5.0$			%	
		Recovery time (mS): $\leq 5.0$			mS	
Output overshoot	Input full voltage range	$\leq 10\%V_o$			%	
Short-circuit protection		It can be short-circuited for a long time and self-recovering			Intermittent	
Drift coefficient	-	-	±0.03%	-	%/°C	
Overcurrent protection	Input full voltage range	$\geq 110\% I_o$ is self-recoverable			Intermittent	
Ripple Noise	-	-	50	80	mV	
	Note: The test method for ripple and noise uses the twisted-pair test method. For specific test procedures and equipment requirements, please refer to the section below (Ripple & Noise Test Instructions).					

### General characteristics

Items	Working conditions	Minimum	Typical	Maximum	Unit
Switching frequency	-	-	65	-	KHz
Operating temperature	-	-25	-	+65	°C
Storage temperature	-	-40	-	+85	
Soldering temperature	Wave soldering	260±4°C, time: 5-10S			
	Hand soldering	360±8°C, interval 4-7S			
Relative humidity	-	10	-	90	%RH

Isolation voltage	Input-output, test for 1 minute, leakage current $\leq 5\text{mA}$	3750	-	VAC
Insulation resistance	Input-output @ apply DC500V	100	-	MΩ
Safety standards	-	EN60950、IEC60950		
Vibration	-	10-55Hz, 10G, 30Min, alongX, Y, Z		
Safety level	-	CLASS II		
Housing grade	-	UL94V-0		
Mean Time Between Failures (MTBF)	-	MIL-HDBK-217F@25°C >300,000H		

EMC Electromagnetic Compatibility Characteristics

Total Project	Sub-projects	Testing standards	Judgment grade
EMC	EMI	Conducted Emission	CISPR22/EN55032 CLASS B (Typical EMC Applications Figure 4)
		Radiated Emission	CISPR22/EN55032 CLASS B (Typical EMC Applications Figure 4)
	EMS	Radiation Immunity	IEC/EN61000-4-3 10V/m Perf. Criteria B
		Conducted Susceptibility	IEC/EN61000-4-6 3Vr. m. s Perf. Criteria B
		Electrostatic Discharge	IEC/EN61000-4-2 Contact $\pm 6\text{KV}$ / Air $\pm 8\text{KV}$ Perf. Criteria B
		Surge Immunity	IEC/EN61000-4-5 $\pm 1\text{KV}$ Perf. Criteria B
		Electrical Fast Transient (EFT) Immunity	IEC/EN61000-4-4 $\pm 2\text{KV}$ Perf. Criteria B
		Immunity to Voltage Sag and Transient, Short Interruption	IEC/EN61000-4-11 0%~70% Perf. Criteria B

Package Dimensions

单位(Unit):mm  
 印刷板俯视图 (Printed board vertical view)  
 栅格间距(lattic spacing):2.54mm(0.1inch)  
 未标注尺寸公差 $\pm 0.25\text{mm}$   
 未注明针脚直径公差 $\pm 0.10\text{mm}$

Package code	L x W x H	
H2	70.0X48.0X23.5 mm	2.756X1.890X0.925inch

Pin Definitions

Pin	1	2	3	4	5	6	7	8
Single (S)	FG	AC (N)	AC (L)	+Vo	NP	NP	NP	-Vo
	No function	Input neutral wire	Input + wire	Output positive terminal	Bare pin	Bare pin	Bare pin	Output negative terminal
Dual common ground (D)	FG	AC (N)	AC (L)	+Vo1	NP	COM	NP	-Vo2
	No function	Input neutral wire	Input + wire	Output positive terminal 1	Bare pin	Common terminal	Bare pin	Output negative terminal 2
Dual isolation (E)	FG	AC (N)	AC (L)	+Vo2	-Vo2	NP	+Vo1	-Vo1
	No function	Input neutral wire	Input + wire	Output positive terminal 2	Output negative terminal 2	Bare pin	Output positive terminal 1	Output negative terminal 1

Note: If the pin assignments of the power module differ from those in the selection guide, refer to the labels on the actual unit.

Ripple & Noise Test Instructions (Twisted Pair Method 20MHz Bandwidth)

Test Method:

1. For ripple and noise testing, use a Category 12 twisted-pair cable. Set the oscilloscope bandwidth to 20 MHz and use a 100 MHz bandwidth probe. Connect a 0.1 μF polypropylene capacitor and a 10 μF high-frequency, low-impedance electrolytic capacitor in parallel at the probe tip. Set the oscilloscope to "Sample" mode.

2. Output Ripple Noise Test Diagram:

Connect the power supply input to the input power source. Connect the power supply output to the electronic load via the fixture board. For testing, use a 30 cm ± 2 cm sampling lead to take a direct sample from the power supply output port. Select insulated wires with appropriate gauge based on the magnitude of the output current.

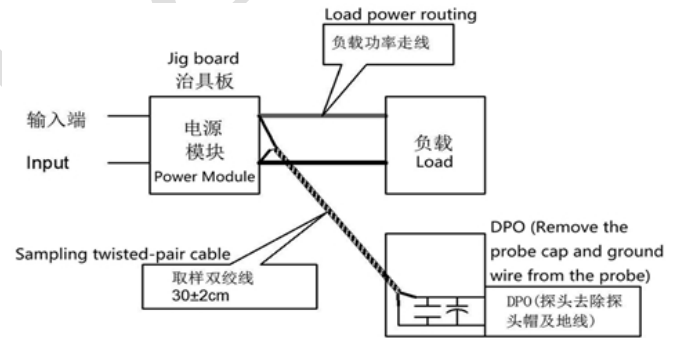

Product characteristic curve

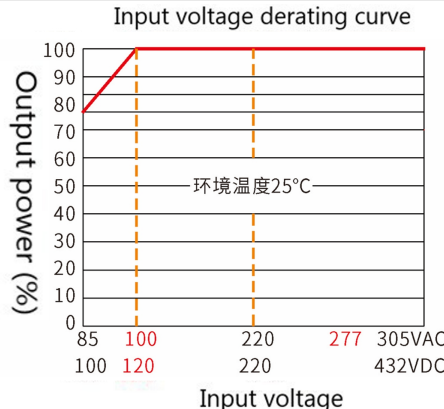
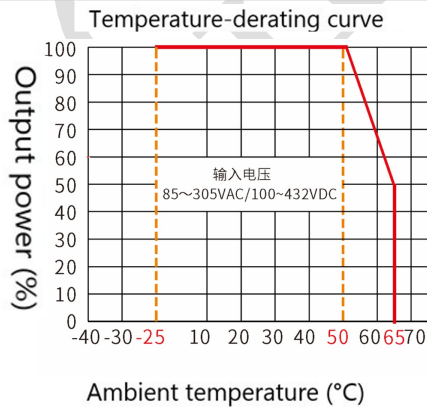

Note 1: The input voltage is 85 - 100 VAC. Voltage derating must be performed based on the input voltage derating curve.

Note 2: This product is designed for use in naturally ventilated environments. Please contact us if you intend to use it in an enclosed environment.

## Typical application circuit diagram and recommended parameters

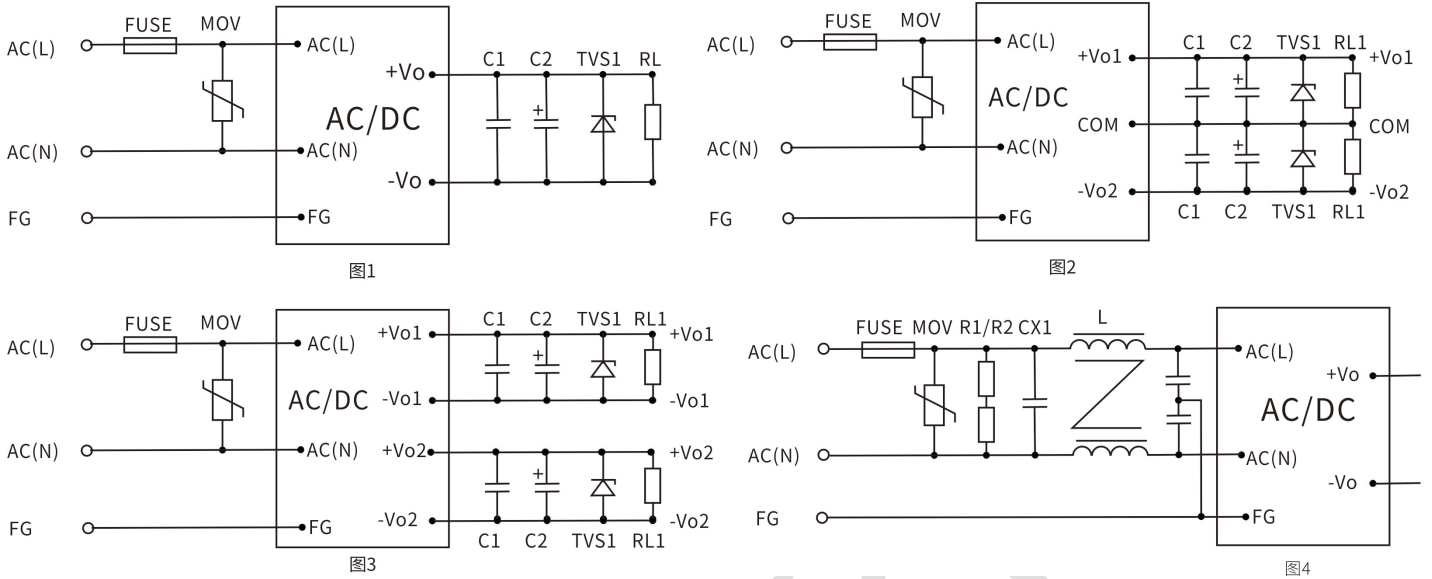

## Note:

- The output filter capacitors C1 and C3 are used to eliminate high-frequency noise. We recommend using  $1\ \mu\text{F}$  ceramic capacitors with a voltage rating derated by more than 80%.
- The output filter capacitors C2 and C4 are electrolytic capacitors. We recommend using high-frequency, low-impedance electrolytic capacitors with a rating of  $100\ \mu\text{F}$  and 1A output current. The capacitors should have a voltage rating derated by more than 80%.
- TVS diodes are recommended to protect the downstream circuitry (in case of module malfunction). Recommended 600W models: For 5V output, use SMBJ7.0A; for 9V output, use SMBJ12.0A; for 12V output, use SMBJ20A; for 15V output, use SMBJ20.0A; for 24V output, use SMBJ30.0A; for 48V output, use SMBJ64A
- MOV stands for Metal Oxide Varistor. Recommended models: 10D561K (1000V surge) or 14D561K (2000V surge). Its function is to protect the module from damage during lightning surges.
- For general application requirements, customers should use the recommended circuits shown in Figures 1, 2, and 3. If EMC certification is required, please use the recommended circuit shown in Figure 4. The specific recommended values for Figure 4 are as follows:
  - Varistor (MOV): Recommended model: 14D-561K; its function is to protect the module from damage during lightning surges.
  - Safety capacitors CY1 and CY2:  $1000\ \text{pF} / 400\ \text{VAC}$ ;
  - Safety capacitor CX:  $0.47\ \mu\text{F} / 275\ \text{VAC}$ ;
  - Common-mode choke LCM:  $20\text{mH} - 30\text{mH}$ ;
  - Discharge power resistors R1/R2:  $510\text{k}\Omega / 0.25\ \text{W}$ ;
  - FUSE: Mandatory; recommended rating:  $3.15\ \text{A} / 250\ \text{V}$ , slow-blow (if the fuse current is too low, it is prone to damage during surges; if too high, it loses its protective function).

## Notes

1. The product must be used within the specified parameters; otherwise, it may be permanently damaged.
2. A fuse must be installed at the product's input terminal.
3. If the product operates below the minimum required load, we cannot guarantee that all performance specifications listed in this manual will be met;
4. If the product operates outside its rated load range, we cannot guarantee that all performance specifications listed in this manual will be met;
5. Unless otherwise specified, all data above was measured at  $T_a=25^{\circ}\text{C}$ , humidity  $<75\%$ , with nominal input voltage and rated output load (pure resistive load);
6. All test methods for the above specifications are based on our company's standards;
7. The above specifications apply to the product models listed in this manual. Certain specifications for non-standard models may exceed the requirements listed above; please contact our technical staff directly for details;
8. We offer product customization;
9. Product specifications are subject to change without notice; please refer to the latest version of the manual published on our official website.

## Contact

# GDHUIZHI<sup>®</sup>

## 广东汇智电子技术有限公司

[Guangdong Huizhi Electronic Technology Co., Ltd.](http://www.huizhi-elec.com)

地址：广东省肇庆市端州区 11 区肇庆大道北侧厂房、办公楼(二期)3 楼

Address: 3rd floor, factory and office building (phase II) on the north side of Zhaoqing Avenue,  
District 11, Duanzhou District, Zhaoqing City, Guangdong Province, China

Homepage: [www.huizhi-elec.com](http://www.huizhi-elec.com)/[www.chinaebizal.com](http://www.chinaebizal.com)

Tel: +86 - 758 - 2566 585

E-mail: [sales@huizhi-elec.com](mailto:sales@huizhi-elec.com)